

Process Book

# SERENITY NORMAN

Diverse Forms | Packaging | Fall 2025

# CREATIVE BRIEF

## **The Diverse Forms:**

Many brands have products that exist in a variety of shapes and forms (consider Gatorade "G" series and similar brands). Identify one of these brands for your project that you think needs design improvement. The challenge of this project is to extend the look of your brand over different sized containers: boxes, cylindrical cartons, bottles, blister packs, etc.

## **Requirements:**

You may choose to retain the original containers, or reimagine the container type. Packaging should maintain the existing content but the surface graphics must change. You must have at least three different forms/sizes, although you may choose to do more. Can be a grocery product, but may also be a non-consumable consumer product.

## **Things to consider:**

Research existing brands, color, form, shelf presence, imagery, typography. How does your design work across disparate forms?

## **Timeline:**

4 weeks

## **Chosen idea:**

A tattoo kit. Includes a tattoo machine and battery, tattoo inks, and tattoo aftercare cream. Would be creating a brand for it from scratch.



# RESEARCH

Serenity Norman | Diverse Forms | Packaging | Fall 2025

# SUBJECT RESEARCH (TATTOO MACHINE)



# SUBJECT RESEARCH (TATTOO INK)

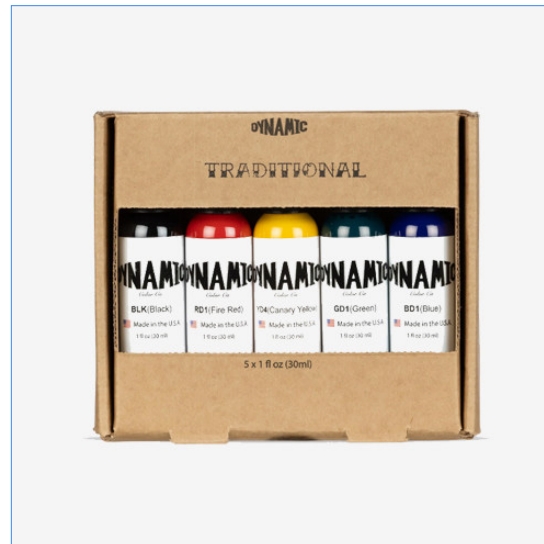

# SUBJECT RESEARCH (TATTOO AFTERCARE)



# SUBJECT RESEARCH (STYLE INSPIRATION)



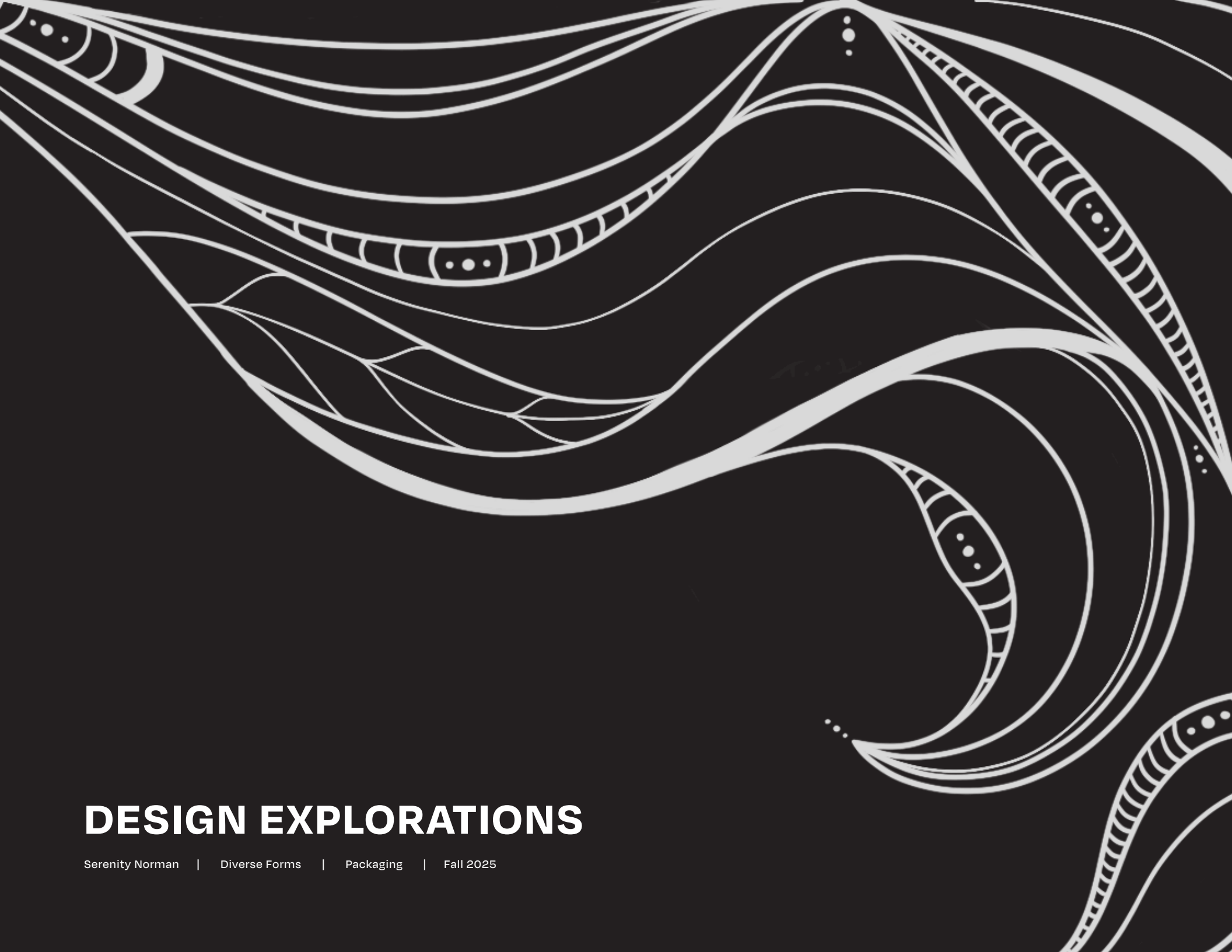

# DESIGN EXPLORATIONS

Serenity Norman | Diverse Forms | Packaging | Fall 2025

# TYPOGRAPHIC EXPLORATIONS

Diverse Forms Brand Name Font  
Options (this is Degular)

Cover Me

*Cover Me*

*Cover Me*

*Cover Me*

*Cover Me*

*Cover Me*

*Cover Me*

*COVER ME*

*Cover Me*

Keywords for the type of font I was going for: elegant, wispy, professional, sleek, script, handwritten, delicate.

I wanted to pick something that falls in line with the words listed above because I figured it would work best with the more limited and professional aesthetic that I chose. Also, something closer to being handwritten as opposed to more technical/standard fonts would work best with the pattern design of the packaging itself.

Ultimately, Tangier (medium) won based on the way the letters flow into each other and the line weight of the strokes (personal nitpicky preference choice).

# TYPOGRAPHIC EXPLORATIONS

Diverse Forms Text Type Font  
Options (this is Degular)

Tattoo

Tattoo

Tattoo

Tattoo

Tattoo

Tattoo

Tattoo

Tattoo

For text type, I just wanted something that matched the brand type and design. Seravek won

# COLOR EXPLORATIONS



To contrast the rest of my portfolio, I wanted to do something different and go for a really limited color palette (or rather, a lack of color). Just plain black and white worked out well for what I wanted.

# NOTES AND SKETCHES

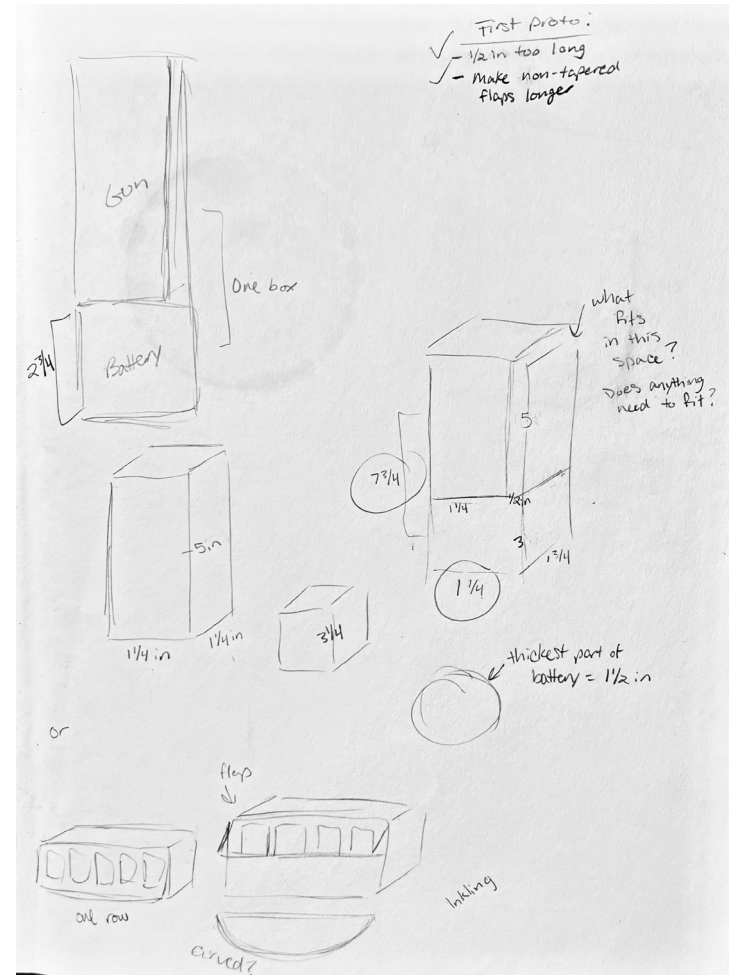
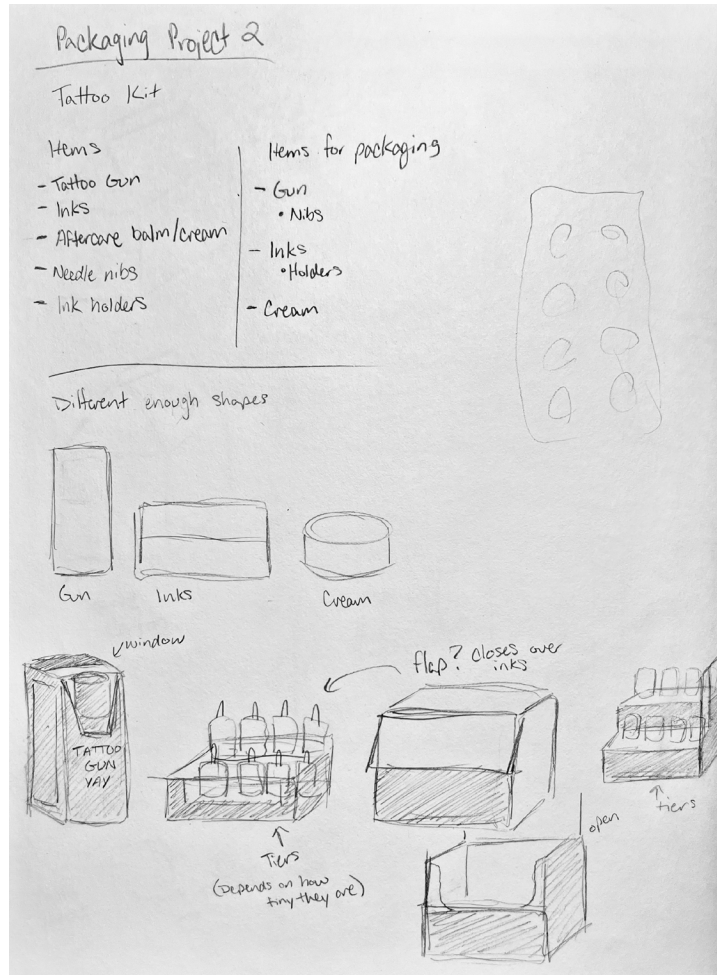

Although they are presented one page after another, none of these pages are "in order". It was really a lot of back and forth between sketching and prototyping and designing. The sketches were mainly used to visualize what I wanted initially and to take measurements and notes on mockup revisions.

# NOTES AND SKETCHES

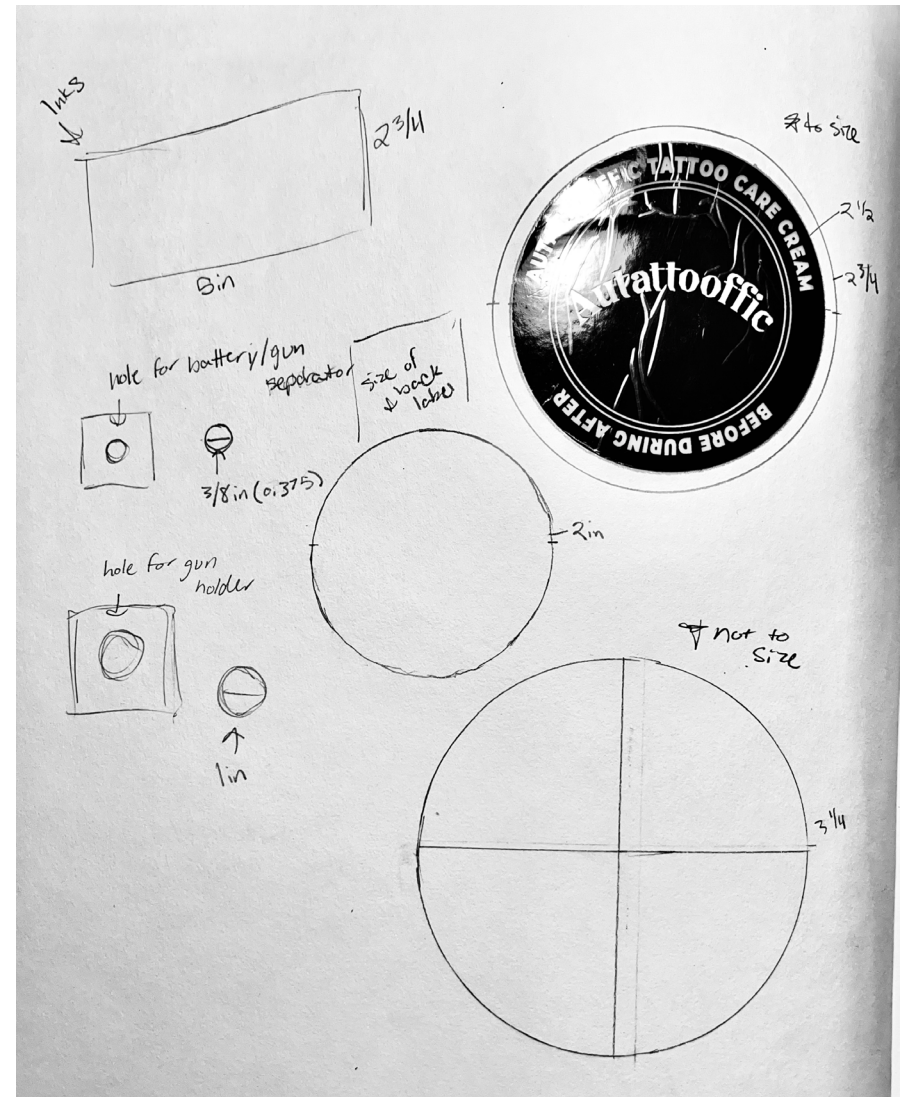
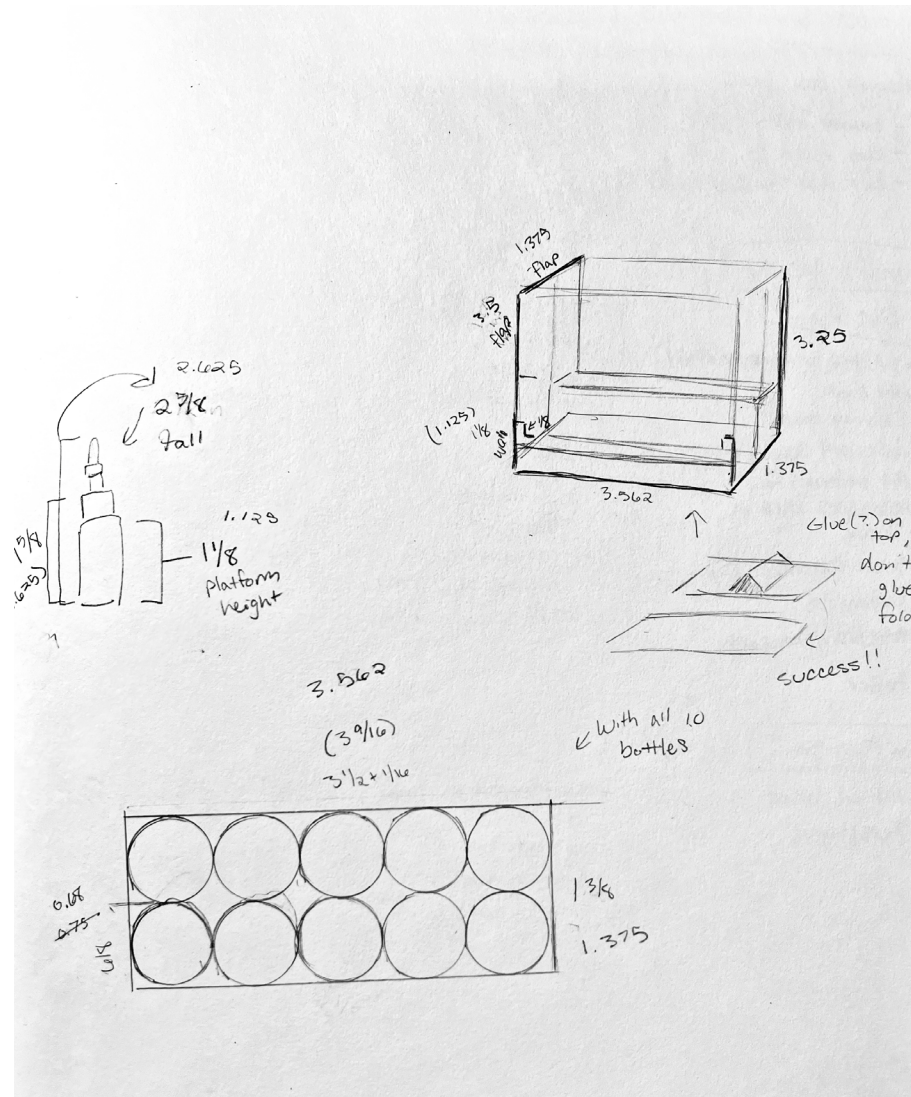

# NOTES AND SKETCHES

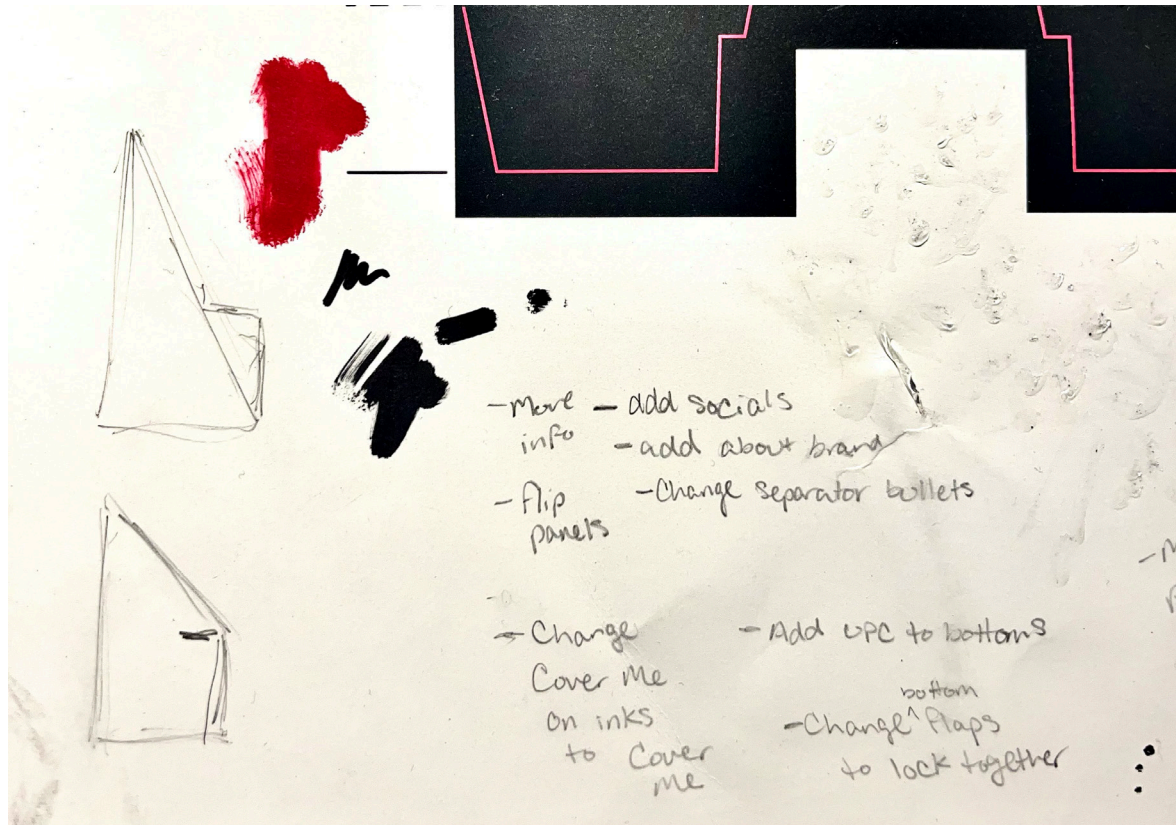

# MOCKUP PROTOTYPES

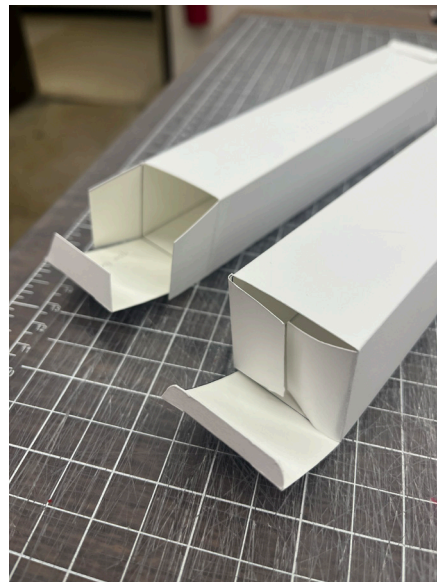
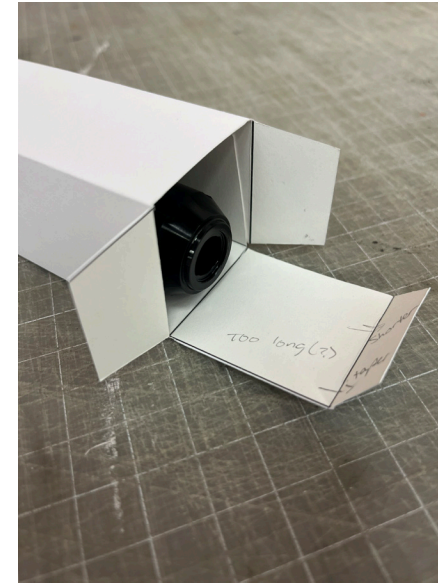
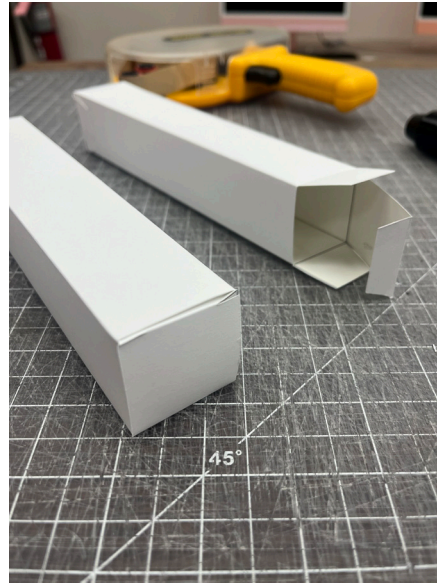
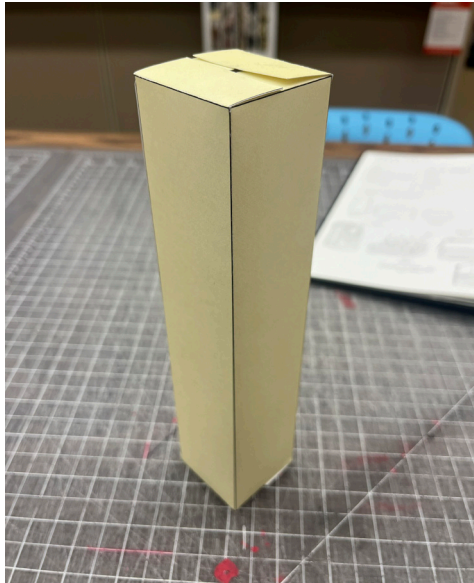

First mockups I did were for the tattoo machine box. Mainly working on the closing mechanisms and the supports to hold the pieces inside the box securely.

# MOCKUP PROTOTYPES

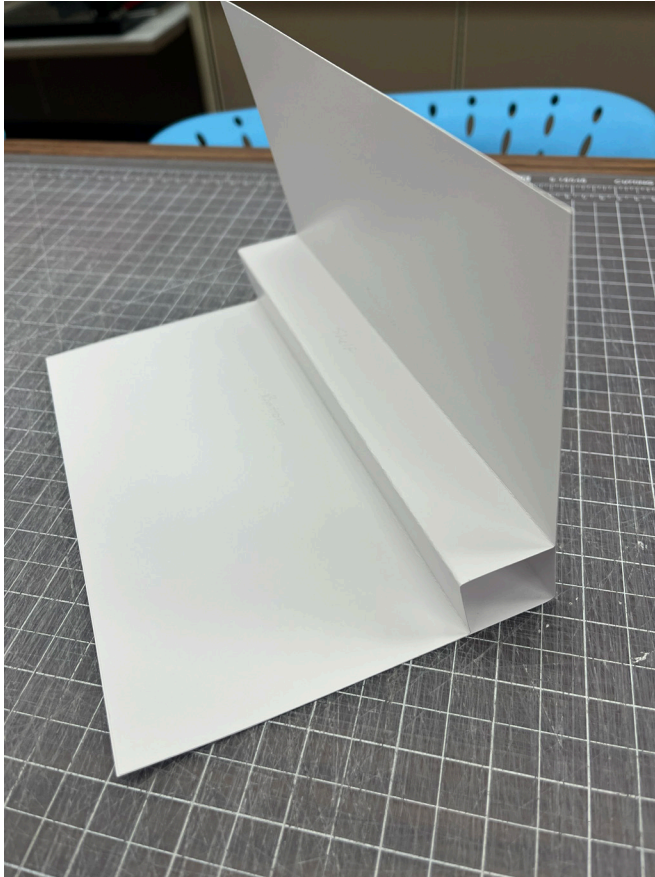

Next step was to figure out the layered tier structure for the ink boxes. I created the ledge by using two sheets of paper. Folding the base in half creates the bottom and the wall, and the top is folded to make the tier. Glue/tape both together except for the folds for the tier, and voila!

# MOCKUP PROTOTYPES

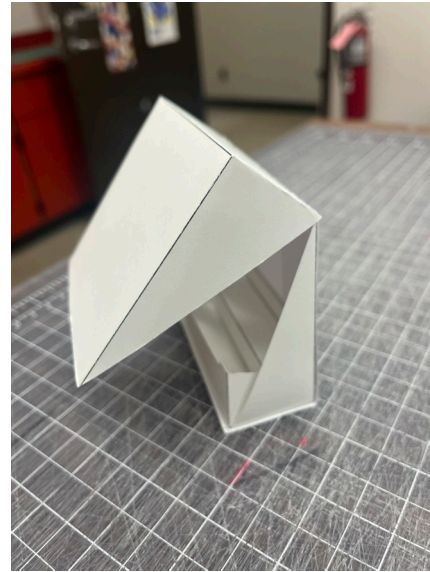
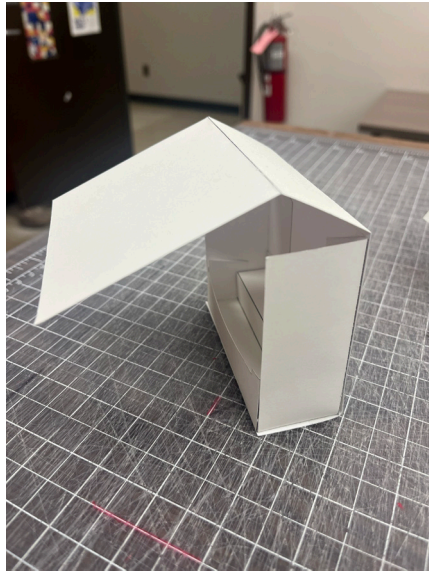
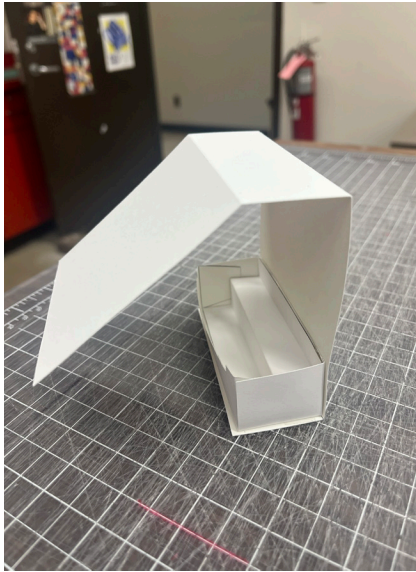

After that was the work for the rest of the ink box. Main thing here was figuring out how it would close as well as what walls and supports were needed for stability. The final box is held shut by magnetic strips so it stays closed.

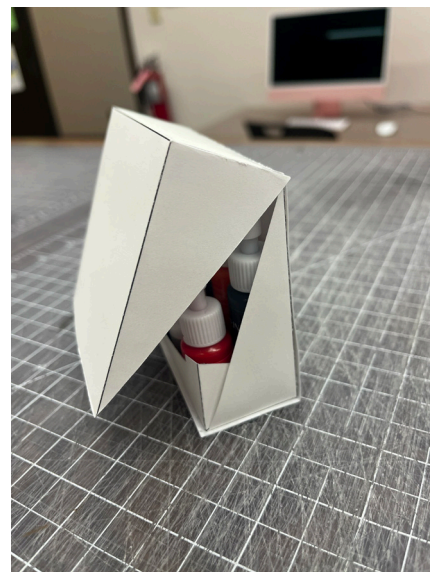

# MOCKUP PROTOTYPES



Picture on the left shows the first round of boxes with the design and type. Multiple revisions were still made after. The second picture shows the first round of the ink box vs the final box (before finishing touches).

# INK DESIGN PROCESS

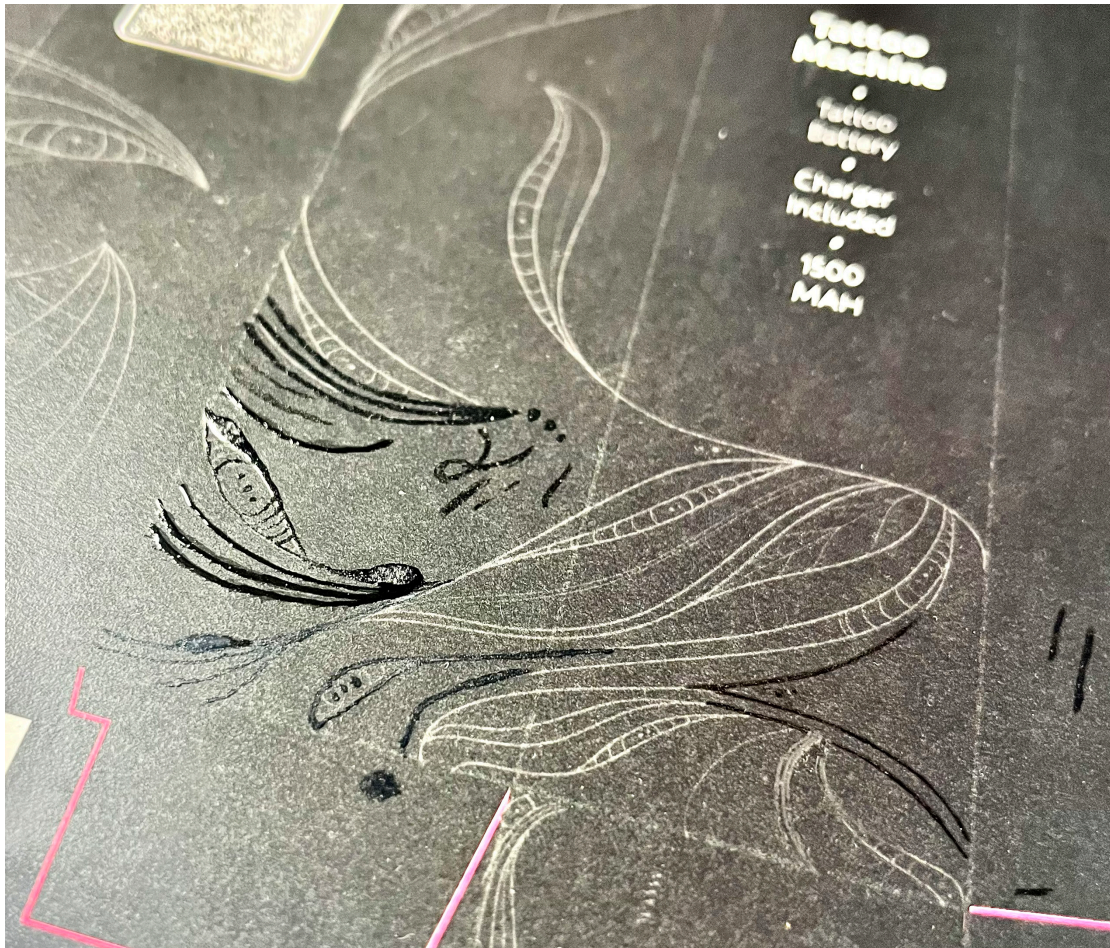

To achieve the black-on-black effect I wanted for the background design, a couple steps (and a lot of dedication and experimentation) were taken.

Here's the first step; trying to figure out what medium worked for the best black effect. The only thing that worked was specifically the Elf H2O Proof Eyeliner Brush Pen. Something in its formula makes it slightly thicker and more reflective than other liners, even ones within the same Elf brand.

Other eyeliners didn't have the same effect, black pens, gel pens, inks, or markers also didn't have the right effect. In the picture, you can see how these different materials showed up.

Once I figured it out, I just traced over the design with it. Before that, I altered the design a bit to make it simpler and easier to trace over.

# INK DESIGN PROCESS



Second step was adding glossy mod podge with a thin brush over the eyeliner to take it over the top. You can see the difference between no mod podge and with the mod podge in the first picture. Second pic is just a chicken scratch sheet I used during the process. The mod podge also added some texture, so when you touch it feels slightly raised.

# THE DESIGNS

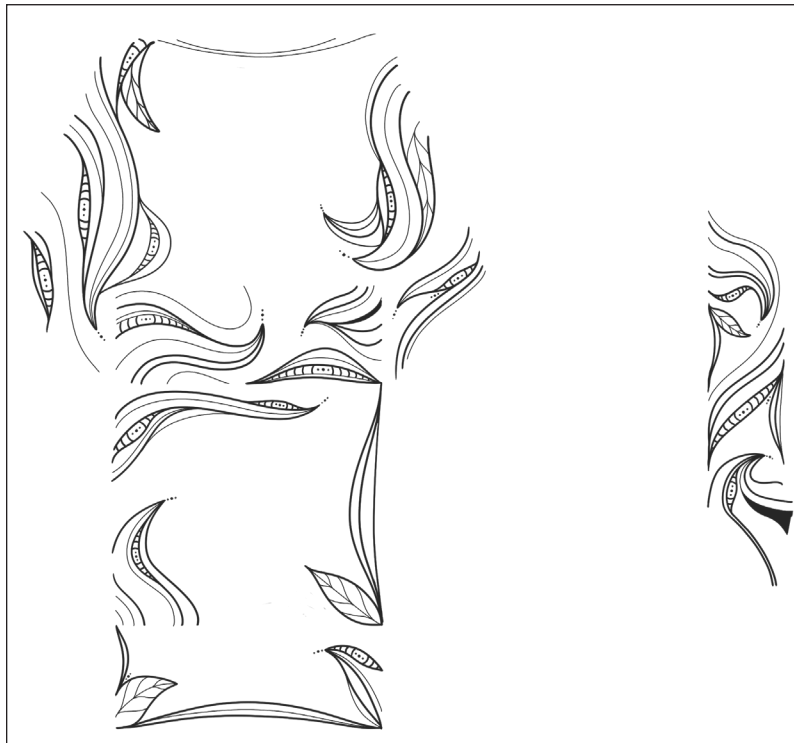
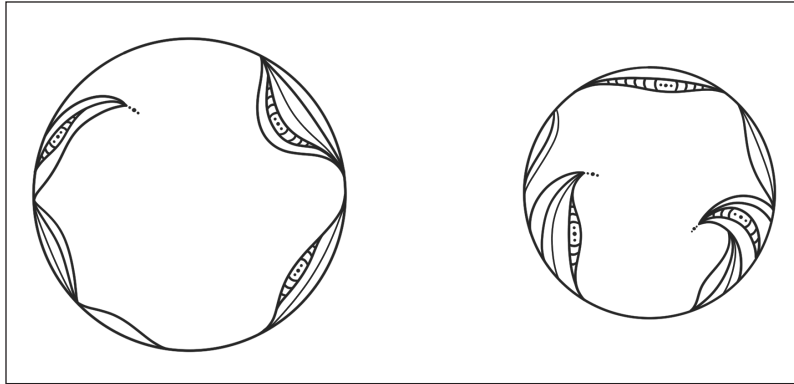

Here are the said designs I came up with. Again, I wanted a pattern that matched those keywords listed earlier. I also wanted something that felt like "tattoo", so I went with a linework design. If I were to be a tattoo artist, this is probably a style I'd like to work in. (Examples below)

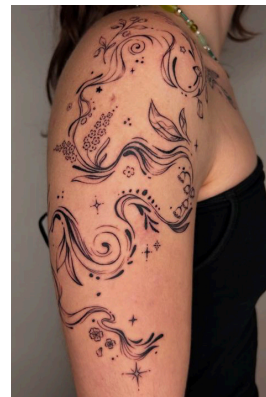

# FINAL DIELINES

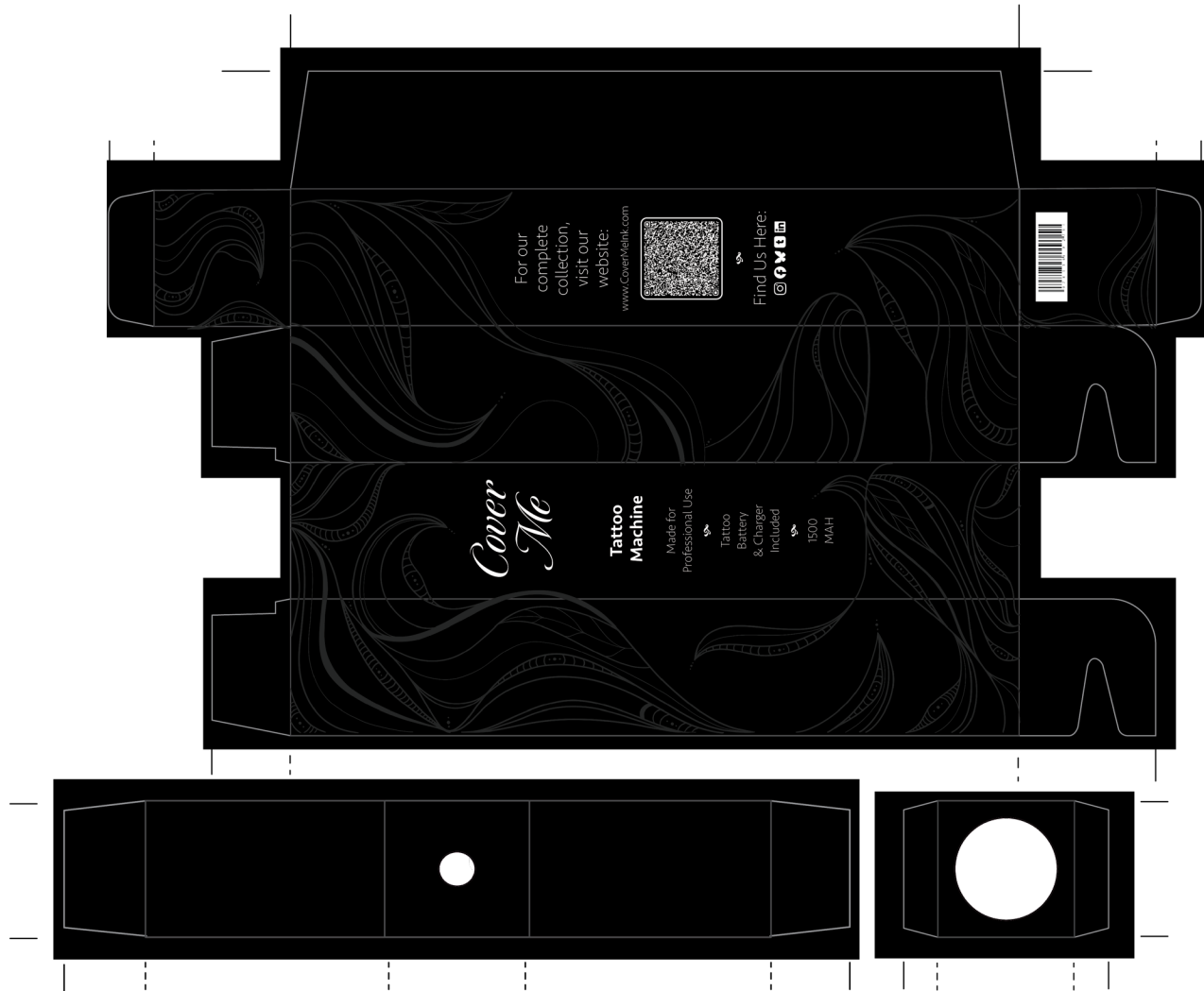

Final measurements (L x W x H): 1.5in x 1.5in x 8in

# FINAL DIELINES



Final measurements (L x W x H): 1.3in x 3.5in x 3.25in

# FINAL DIELINES



Final measurements: (Front label) 2.5in (Back label) 2in

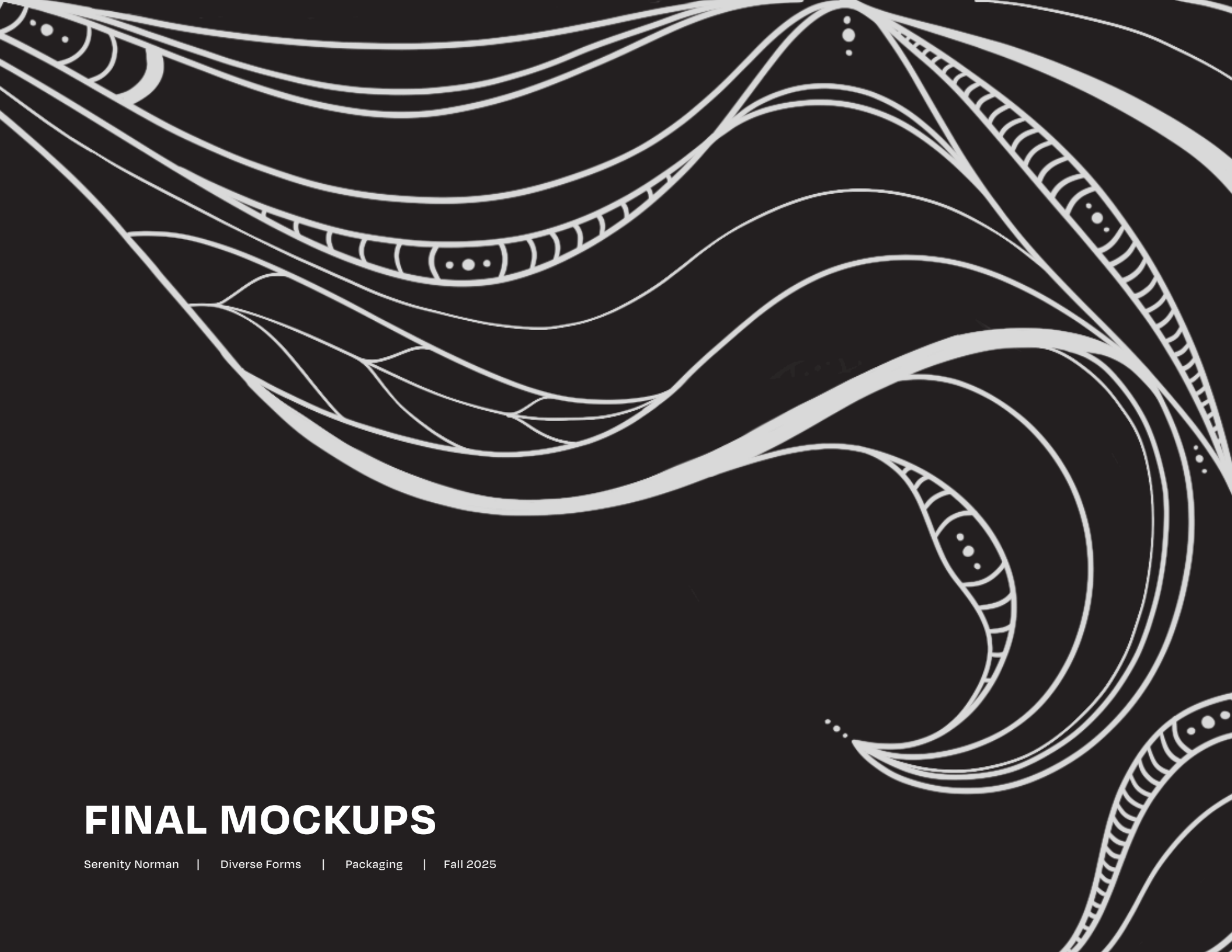

# FINAL MOCKUPS

Serenity Norman | Diverse Forms | Packaging | Fall 2025

# FINAL MOCKUPS



# FINAL MOCKUPS

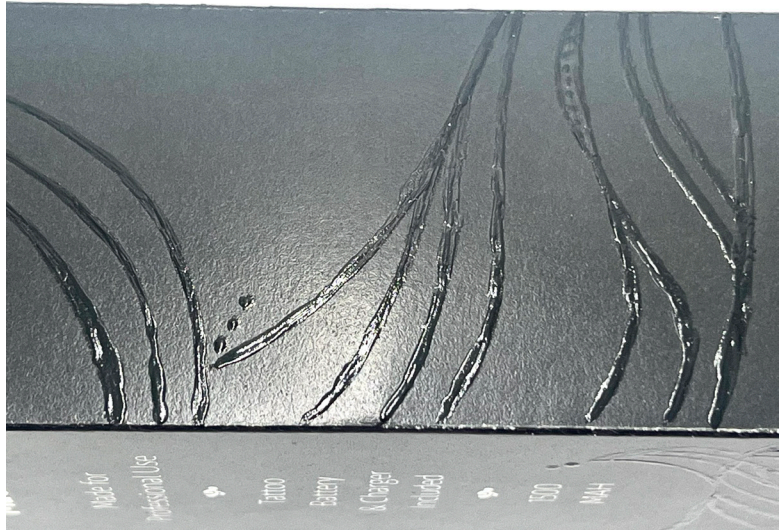

# FINAL MOCKUPS



# FINAL MOCKUPS



# FINAL MOCKUPS

